

Potain Igo 50

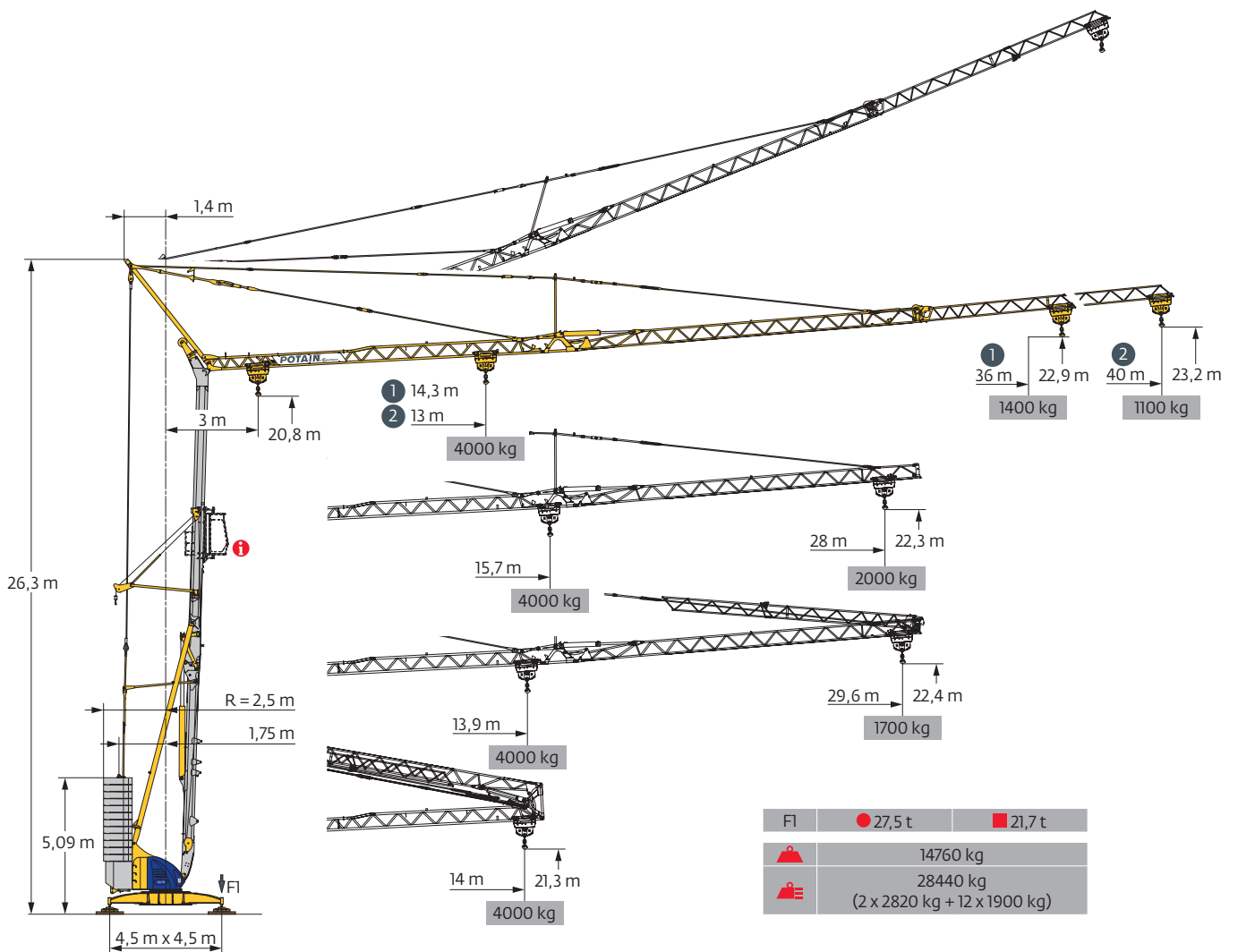

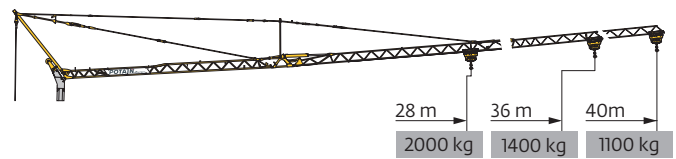



Courbes de charges / Lastkurven / Load curves / Curvas de cargas / Curve di carico
 Curvas de carga / Кривые нагрузок

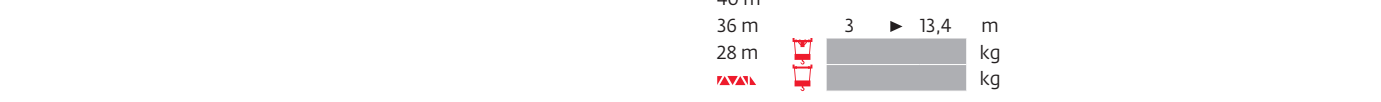
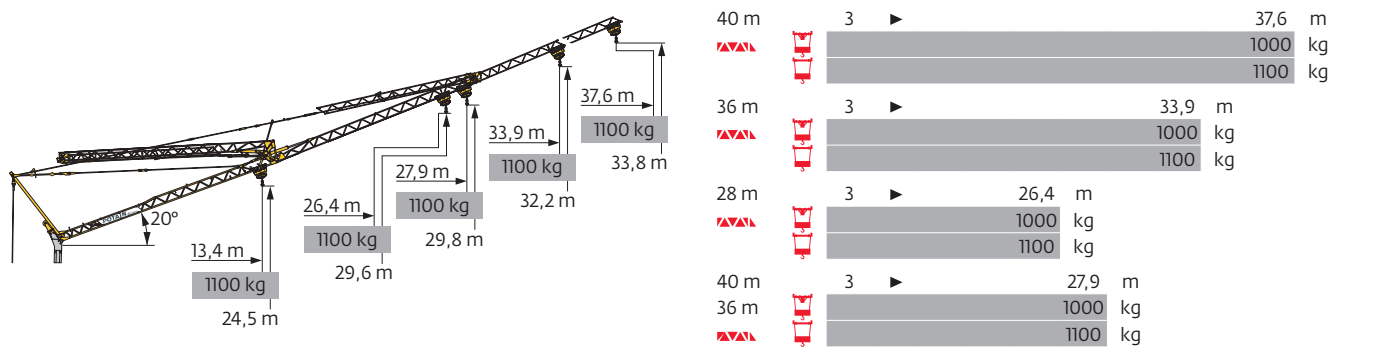
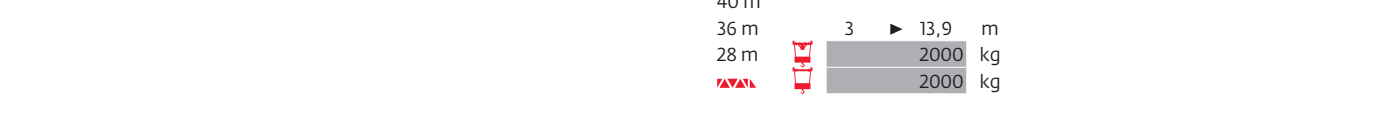
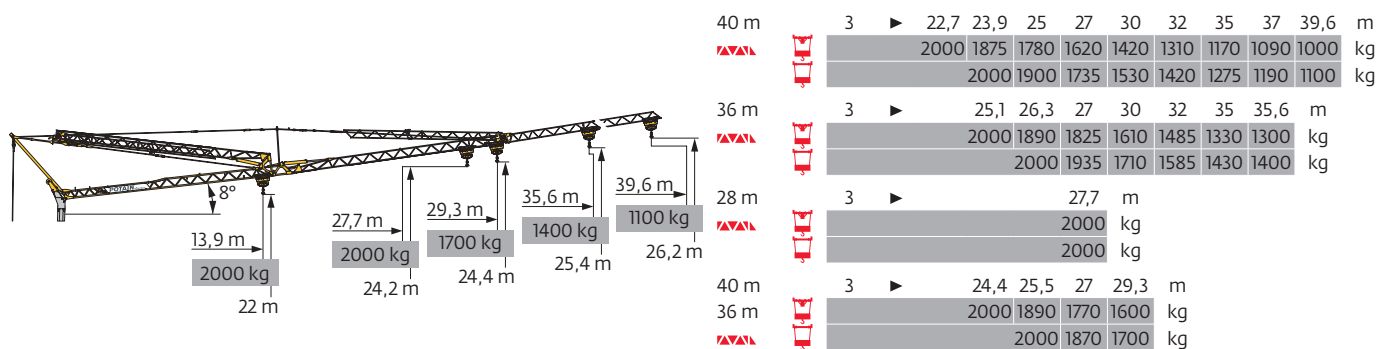
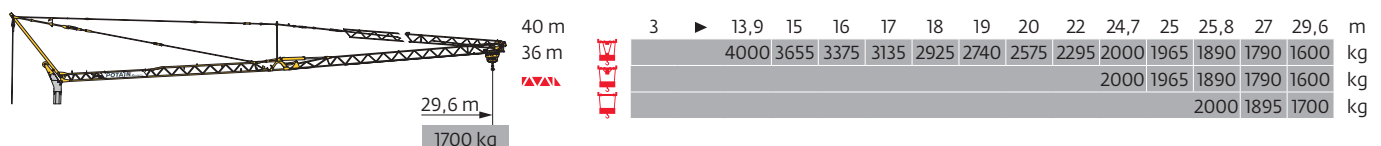



40 m	3	▶	14	m		3	▶	13	14	15	16	17	18	19	20	23	24,2	25	27	30	32	35	37	40	m	
▲▲▲	▲▲▲				4000	kg			4000	3665	3365	3105	2885	2690	2520	2365	2000	1875	1800	1640	1440	1330	1185	1105	1000	kg
					2000	kg											2000	1875	1800	1640	1440	1330	1185	1105	1000	kg
					2000	kg											2000	1920	1755	1550	1435	1290	1210	1100	kg	
36 m	3	▶	14	m		3	▶	14,3	15	16	17	18	19	20	22	24	25,3	26,6	27	30	32	35	36	m		
▲▲▲	▲▲▲				4000	kg			4000	3770	3485	3235	3020	2830	2660	2370	2135	2000	1890	1850	1630	1505	1345	1300	kg	
					2000	kg												2000	1890	1850	1630	1505	1345	1300	kg	
					2000	kg												2000	1960	1735	1610	1450	1400	kg		
28 m	3	▶	14	m		3	▶		15,7	17	18	19	20	22	23	25	26	27	28	m						
▲▲▲	▲▲▲				4000	kg			4000	3635	3395	3180	2990	2670	2530	2290	2190	2090	2000	kg						
					2000	kg													2000	kg						
					2000	kg													2000	kg						



Mécanismes / Triebwerke / Mechanisms / Mecanismos / Meccanismi
 Mecanismos / Механизмы

400 V - 50 Hz 480 V - 60 Hz												ch - PS hp	kW	
	15 LVF 10 Optima	m/min	3,6	18	30	54	66	1,8	9	15	27	33	15	11
		kg	2000	2000	2000	1000	500	4000	4000	4000	2000	1000		
	3 DVF 5	m/min	15- 30 - 45 (0 → 1000kg) 15 - 30 - 41 (1000 → 4000 kg)									3	2,2	
	RVF 51 Optima+	tr/min U/min rpm	0 → 0,8									5,5	4	

 IEC 60204-32	 kVA
400 V (+10% -10%) 50 Hz 480 V (+6% -10%) 60 Hz	23 kVA

15 LVF 10 Optima

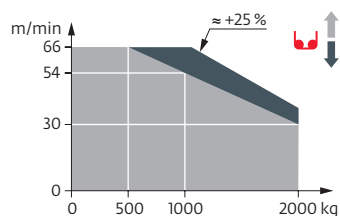

Montage / Montage / Erection / Montaje / Montaggio
 Montagem / Монтаж

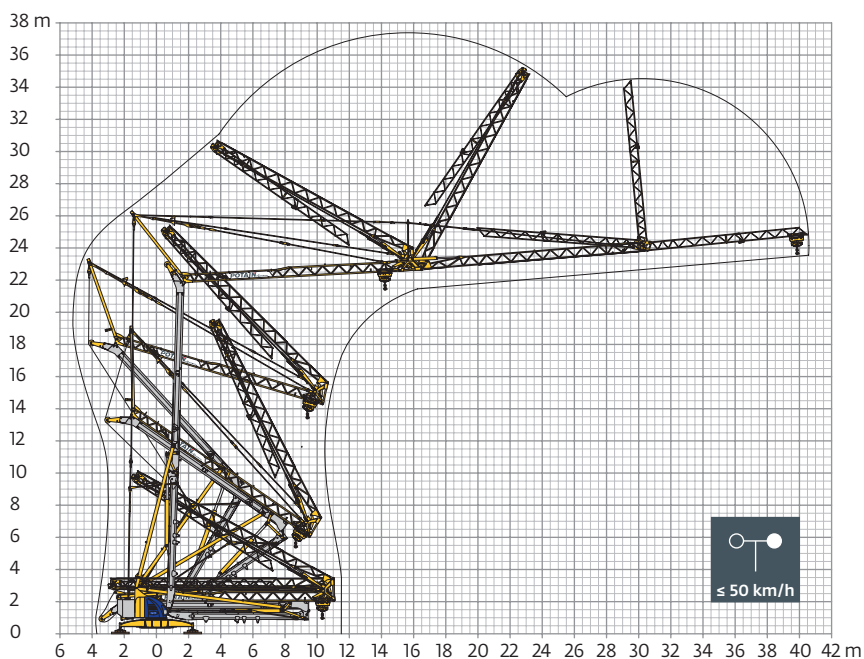

Transport / Transport / Transport / Transporte / Trasporto
Transporte / Транспортировка

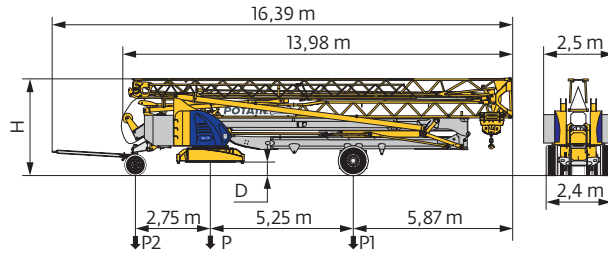

	km/h	D (m)	H (m)	P (kg)	P1 (kg)	P2 (kg)
DJ100/S120	10	0,35/0,2	3,57/3,42	21655	11725	9930
DJ105/S125	25	0,35/0,2	3,57/3,42	21945	11945	10000
..... /..... i						

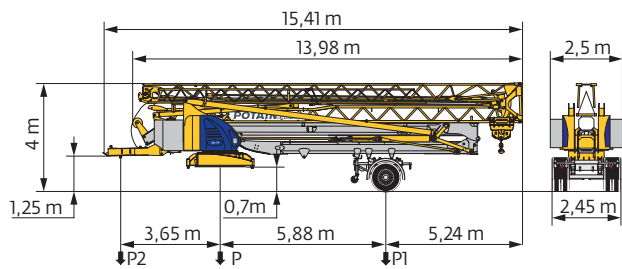

	km/h	P (kg)	P1 (kg)	P2 (kg)
SL121/J135	25	22495	13000	9495
..... /..... i				

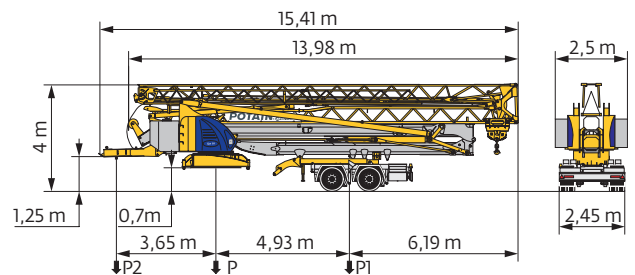

	km/h	P (kg)	P1 (kg)	P2 (kg)
SL121/S215M	25	23740	15490	8250
SL122/J215M	80	23650	15400	8250
..... /..... i				

FR

DE

EN

ES

IT

PT

RU

R	Rayon de giration	Schwenk radius	Rear slewing radius	Radio de giro	Raggio di rotazione	Raio de rotação	Задний габарит
i	Nous consulter	Auf Anfrage	Consult us	Consultarnos	Consultateci	Consultar-nos	Проконсультируйтесь у нас
●	Réactions en service	Reaktionskräfte in Betrieb	Reactions in service	Reacciones en servicio	Reazioni in servizio	Reacções em serviço	Реакция при работе
■	Réactions hors service	Reaktionskräfte außer Betrieb	Reactions out of service	Reacciones fuera de servicio	Reazioni fuori servizio	Reacções fora de serviço	Реакция в покое
⚖	Poids à vide, sans lest, sans trains de transport, avec flèche maxi. et hauteur standard.	Gewicht ohne Last, ohne Ballast, ohne Transportachsen, mit max. Auslager und Standardhöhe	Weight without load, without ballast, without transport axes, with max. jib and standard height	Peso en vacío, sin lastre, sin trenes de transporte con flecha y altura estandar	Peso a vuoto, senza zavorra, senza assali di trasporto, con braccio max e altezza standard.	Peso em vazio, sem lastro, sem eixos de transporte com lança máxima e altura standard.	Вес без груза, без балласта, без осей для транспортировки, с максимальным вылетом стрелы и стандартной высотой
⚖	Poids total du lest	Ballast-Gesamtgewicht	Total ballast weight	Peso total del lastre	Peso totale della zavorra	Peso total do lastro	Общий вес балласта
⬆	Levage	Heben	Hoisting	Elevación	Sollevamento	Elevação	Подъем
⬆	Distribution	Katzfahren	Trolleying	Distribución	Distribuzione	Distribuição	Перемещение по стреле
🔄	Orientation	Schwenken	Slewing	Orientación	Rotazione	Rotação	Поворот
kVA	Puissance nominale	Nennleistung	Rated power	Potencia nominal	Potenza nominale	Potência nominal	Номинальная мощность

⚠	Document commercial non contractuel. Pour toute information technique se référer à la notice correspondante.	Unverbindliches Vertriebsdokument. Für technische Informationen, siehe die entsprechenden Anweisungen.	This commercial document is not legally binding. For any technical information, please refer to the corresponding instructions.	Documento commercial no contractual. Para cualquier información técnica, ver la noticia correspondiente.	Documento commerciale non vincolante, per tutte le informazioni tecniche fare riferimento al catalogo istruzioni.	Documento comercial não contractual. Para qualquer informação técnica complementar consultar as respectivas instruções.	Этот коммерческий документ не является юридически обязательным. Для получения технической информации, см. соответствующие инструкции.
----------	--	--	---	--	---	---	---



Manitowoc - Americas
Manitowoc, Wisconsin, USA
Tel: +1 920 684 6621
Fax: +1 920 683 6277

Shady Grove, Pennsylvania, USA
Tel: +1 717 597 8121
Fax: +1 717 597 4062

Manitowoc - Europe, Middle East & Africa
Ecully, France
Tel: +33 (0)4 72 18 20 20
Fax: +33 (0)4 72 18 20 00

Manitowoc - Asia & Pacific
Shanghai, China
Tel: +86 21 6457 0066
Fax: +86 21 6457 4955